

H&S

PARTS BOOK

24/26 CHASSIS

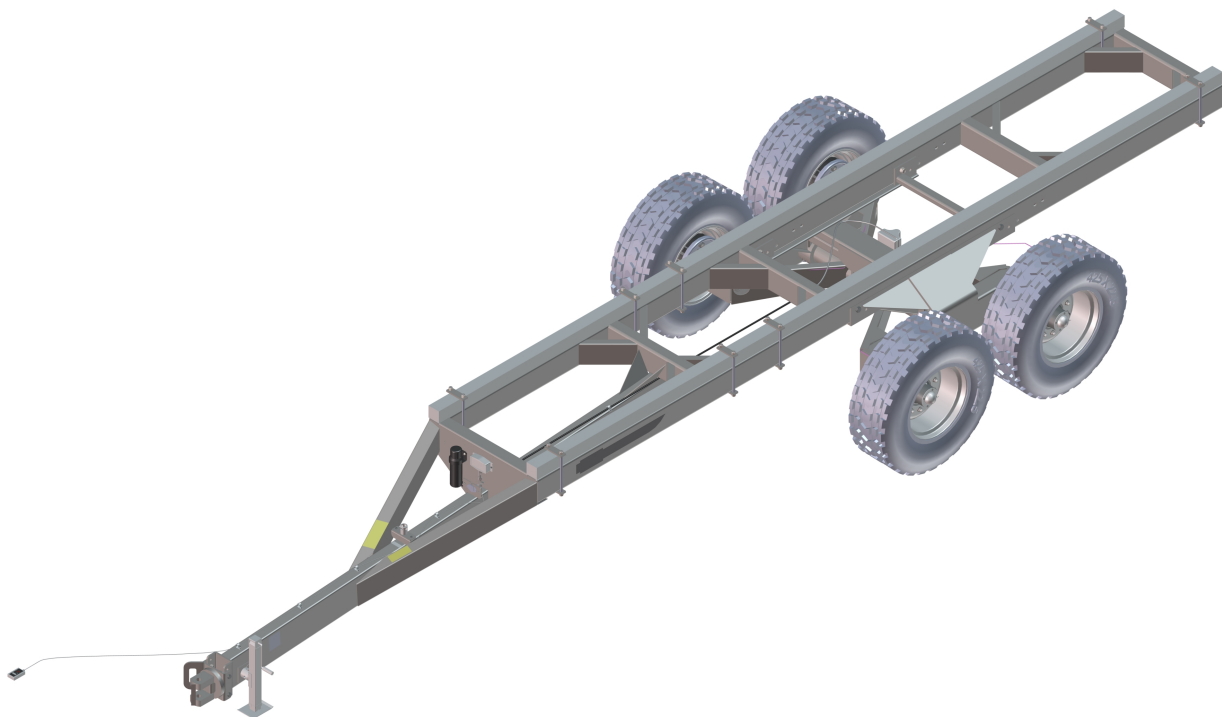

Revision #01
Starting Ser. #911CH26001

Part #74103
HSMFG0817

P.O. BOX 768, MARSHFIELD, WI 54449
(715) 387-3414 FAX (715) 384-5463
www.hsmfgco.com

CONTENTS

Instructions for Ordering Parts - About Improvements	1
Figure 1 - Main Frame & Components	2-3
Figure 2 - Slider Mount Assembly	4-5
Figure 3 - Tandem & Components	6-7
Figure 4 - Optional Brake Harness Assembly	8-9
Figure 5 - Optional Brake Line Assembly	10-11
Figure 6 - Optional Brake Assembly.....	12-13
Notes	14

INSTRUCTIONS FOR ORDERING PARTS

All service parts should be ordered through your authorized H&S dealer. They will be able to give you faster service if you will provide them with the following

1. Model & Serial number is located on the left, rear main frame of your unit.
2. All reference to left or right apply to the machine as viewed from the rear.
3. Parts should not be ordered from illustration only. Please order by complete part number.
4. If your dealer has to order parts - give shipping instructions:
VIA truck - large pieces (please specify local truck lines)
VIA United Parcel Service (include full address)

H&S MFG. CO. INC.	
MARSHFIELD, WIS.	
MOD. NO.	<input type="text"/>
SER. NO.	<input type="text"/>
DESCR.	<input type="text"/>

PLEASE RECORD NUMBERS FOR YOUR UNIT FOR QUICK REFERENCE

ABOUT IMPROVEMENTS

H&S IS CONTINUALLY STRIVING TO IMPROVE IT'S PRODUCTS

We must therefore, reserve the right to make improvements or changes whenever it becomes practical to do so without incurring any obligation to make changes or additions to the equipment previously sold.

FIGURE 1
MAIN FRAME & COMPONENTS

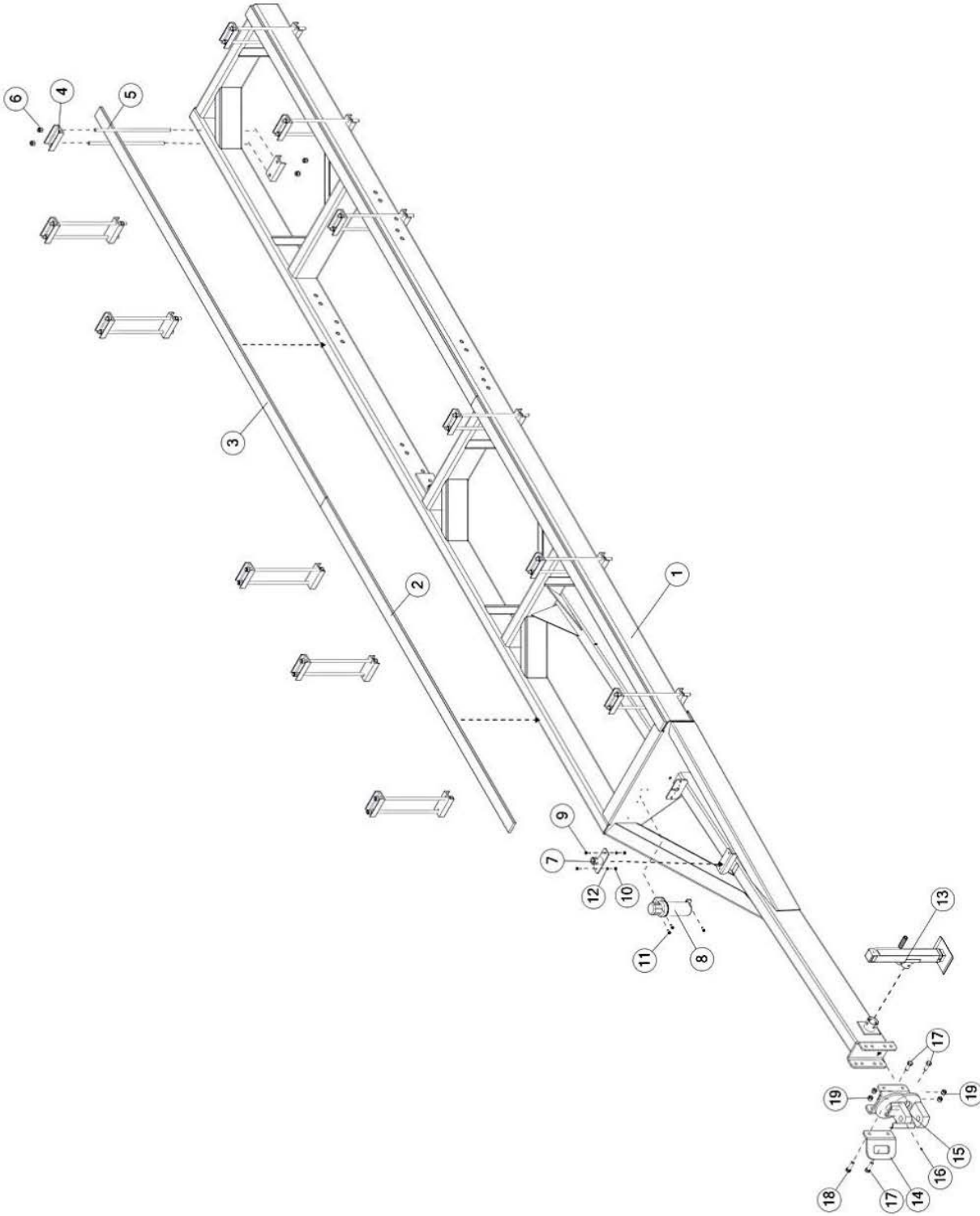

FIGURE 1

MAIN FRAME & COMPONENTS

<u>ITEM</u>	<u>QTY</u>	<u>PART #</u>	<u>DESCRIPTION</u>
1	1	FBC10	FRAME
2	2	70636	REAR WOOD CHASSIS SPACER FRONT
3	2	70634	WOOD CHASSIS SPACER
4	16	69906	TIE DOWN, CHL, C, 3.00 X 1.52 X 6.50
5	16	FBC6	SPACER BOLT
6	32	YNNY24006	NUT HEX , NYLON LOCKNUT, 3/4 (FINE)
7	1	FBC67	BULLDOG MOUNT
8	1	S522	MANUAL HOLDER
9	2	YBHH12010	BOLT HEX, 3/8 X 1 G5
10	2	YNHX12005	NUT HEX, 3/8
11	3	YSST10005	SELF THREADING, FLANGE BOLT, .312 X 1
12	2	YWLO12005	WASHER LOCK, 3/8
13	1	TS306	SQUARE JACK, 7000 LBS (15 TRAVEL)
14	1	FBC27	SAFETY CHAIN MOUNT
*	1	SC60000	SAFETY CHAIN (60,000 LBS)
15	1	FBC9	COMPLETE SWIVEL HITCH
16	1	G89	STRAIGHT ZERK, 1/4
17	3	YBHH24017	BOLT HEX, 3/4 X 2 G8
18	4	YBHH24031	BOLT HEX, 3/4 X 2-1/2 G8
19	4	YNNY24006	NUT HEX, NYLON LOCKNUT, 3/4 (FINE)

***MEANS NOT SHOWN**

FIGURE 2 **SLIDER MOUNT ASSEMBLY**

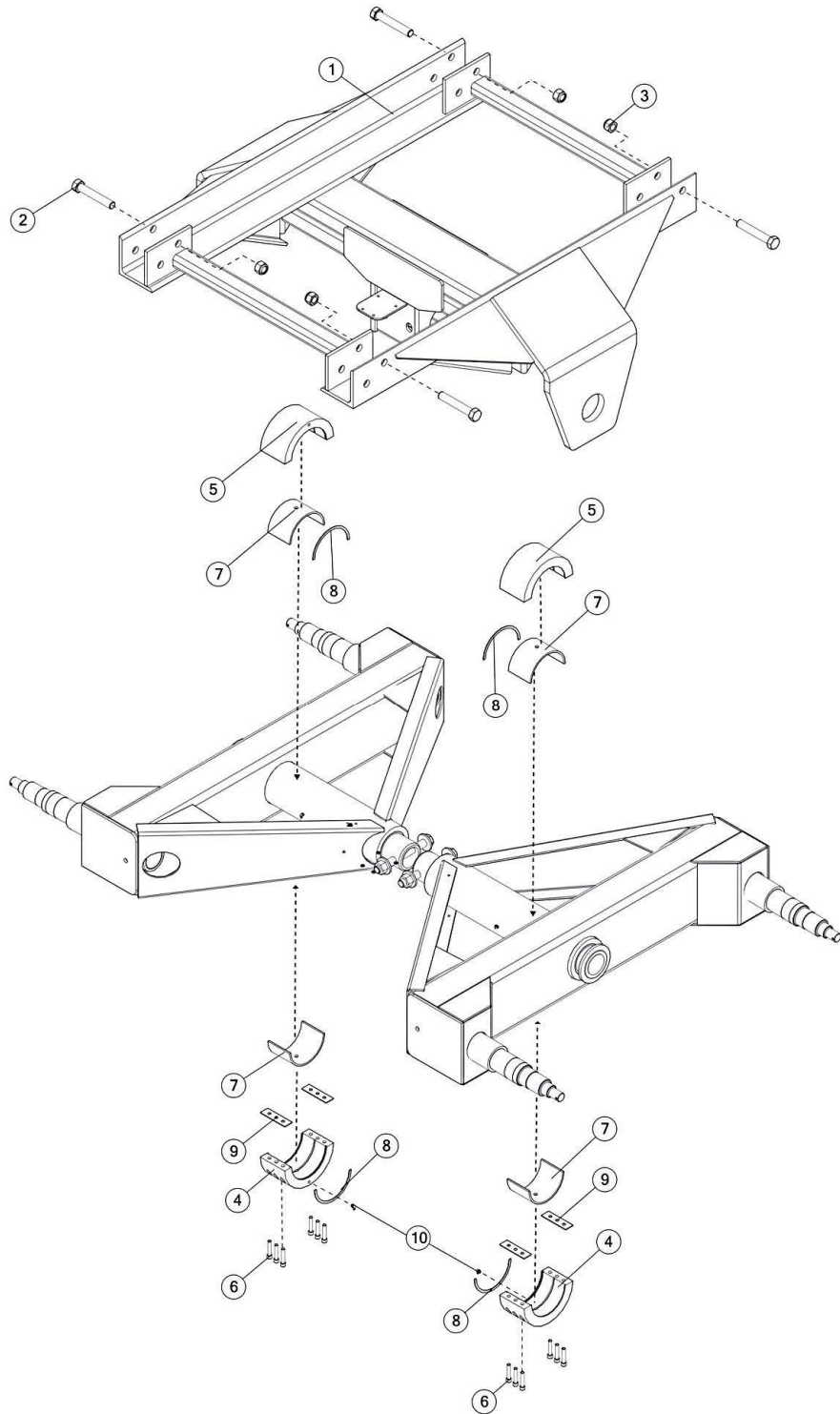

FIGURE 2
SLIDER MOUNT ASSEMBLY

<u>ITEM</u>	<u>QTY</u>	<u>PART #</u>	<u>DESCRIPTION</u>
1	1	FBC13	SLIDER
2	4	YBHH32025	BOLT HEX, 1 X 6 G5
3	4	YNNY32005	NUT HEX, NYLON LOCKNUT, 1
4	2	FBC19	SADDLE BOTTOM
5	2	FBC18	POLY BUSHING
6	12	YSHS14017	SOCKET HEAD, CAP SCREW, 7/16 X 2-1/4
7	4	FBC18	POLY BUSHING
8	4	FBC29	PHENOLIC KEEPER
9	4	FBC24	SADDLE SHIM
10	2	GM503	PIPE ZERK, 1/8, 90 DEGREE

FIGURE 3 TANDEM & COMPONENTS

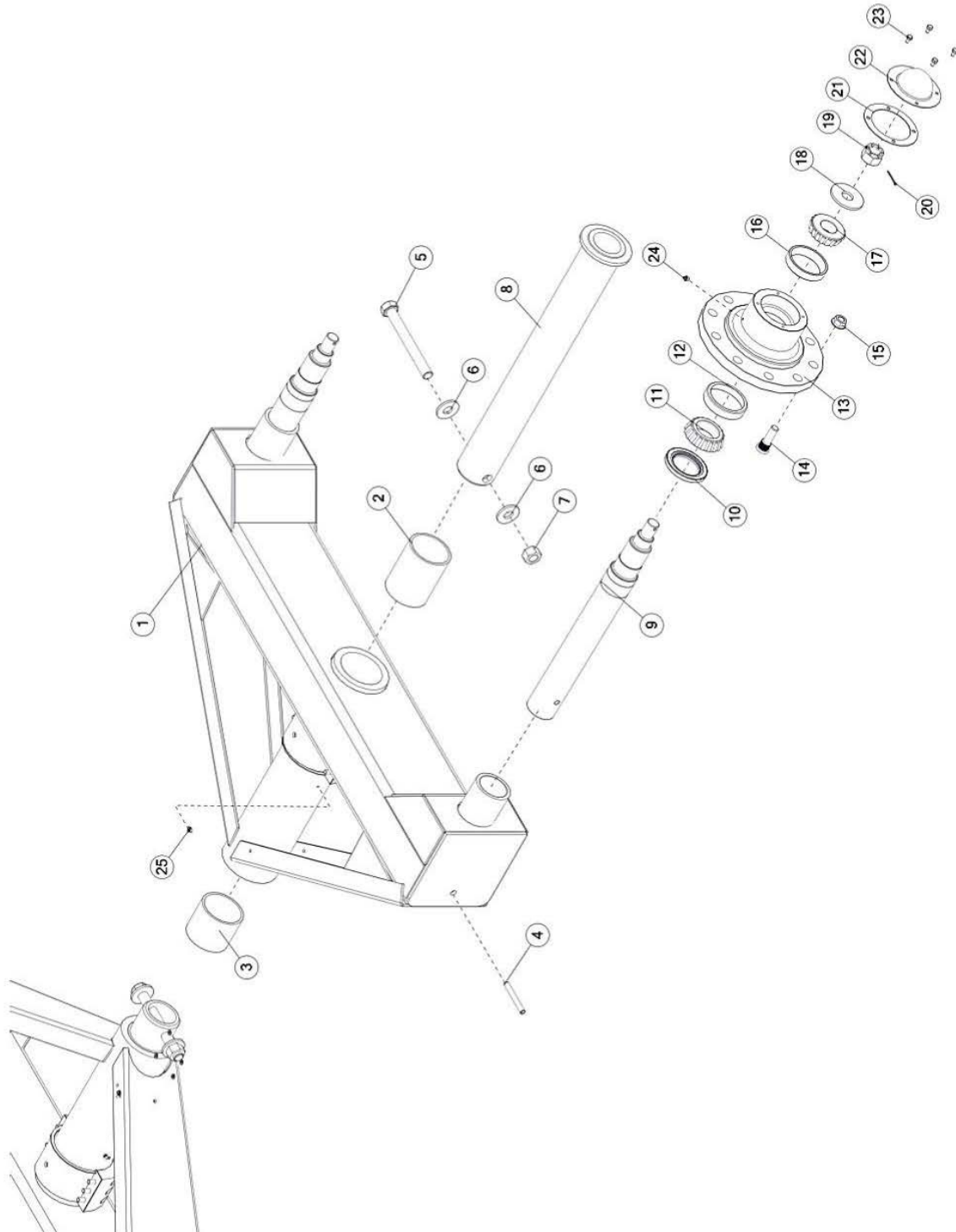

FIGURE 3

TANDEM & COMPONENTS

<u>ITEM</u>	<u>QTY</u>	<u>PART #</u>	<u>DESCRIPTION</u>
1	1	FBC33	TANDEM BEAM RH
*	1	FBC32	TANDEM BEAM LH
2	2	FBC16	POLY BUSHING
3	2	FBC17	POLY BUSHING
4	4	YPEX16020	EXPANSION PIN, 1/2 X 4
5	2	YBHH32040	BOLT HEX, 1 X 9 G5
6	4	FBC26	TANDEM BOLT WASHER
7	2	YNRL32005	NUT HEX , REVERSIBLE-SIDE LOCK, 1
8	2	FBC14	AXLE PIVOT TUBE
9	4	FBC31	TANDEM SPINDLE
10	4	60N5	SEAL
11	4	60N7	INNER BEARING
12	4	60N6	INNER RACE
13	4	54492	HUB WITH TIMKEN BEARINGS, 10 BOLT
14	40	YBSD24010	STUD BOLT, 3/4 UNF X 2-3/4 (3/4 SHOULDER)
15	40	60N14	NUT HEX, FLANGE , 3/4 UNF-28, G8
16	4	60N10	OUTER RACE
17	4	60N9	OUTER BEARING
18	4	60N2	SPINDLE WASHER
19	4	YNCA36005	NUT HEX , CASTLE, 1-1/4
20	4	YPCT07005	COTTER PIN, 3/16 X 2
21	4	56234	HUB CAP GASKET
22	4	60N11	HUB CAP
23	16	YBHH10020	BOLT HEX, 5/16 X 1/2 G5
24	4	BFR28	GREASE ZERK, 1/8 NPT
25	2	RG51	GREASE ZERK, 1/4, 90 DEGREE

***MEANS NOT SHOWN**

FIGURE 4 OPTIONAL BRAKE HARNESS ASSEMBLY

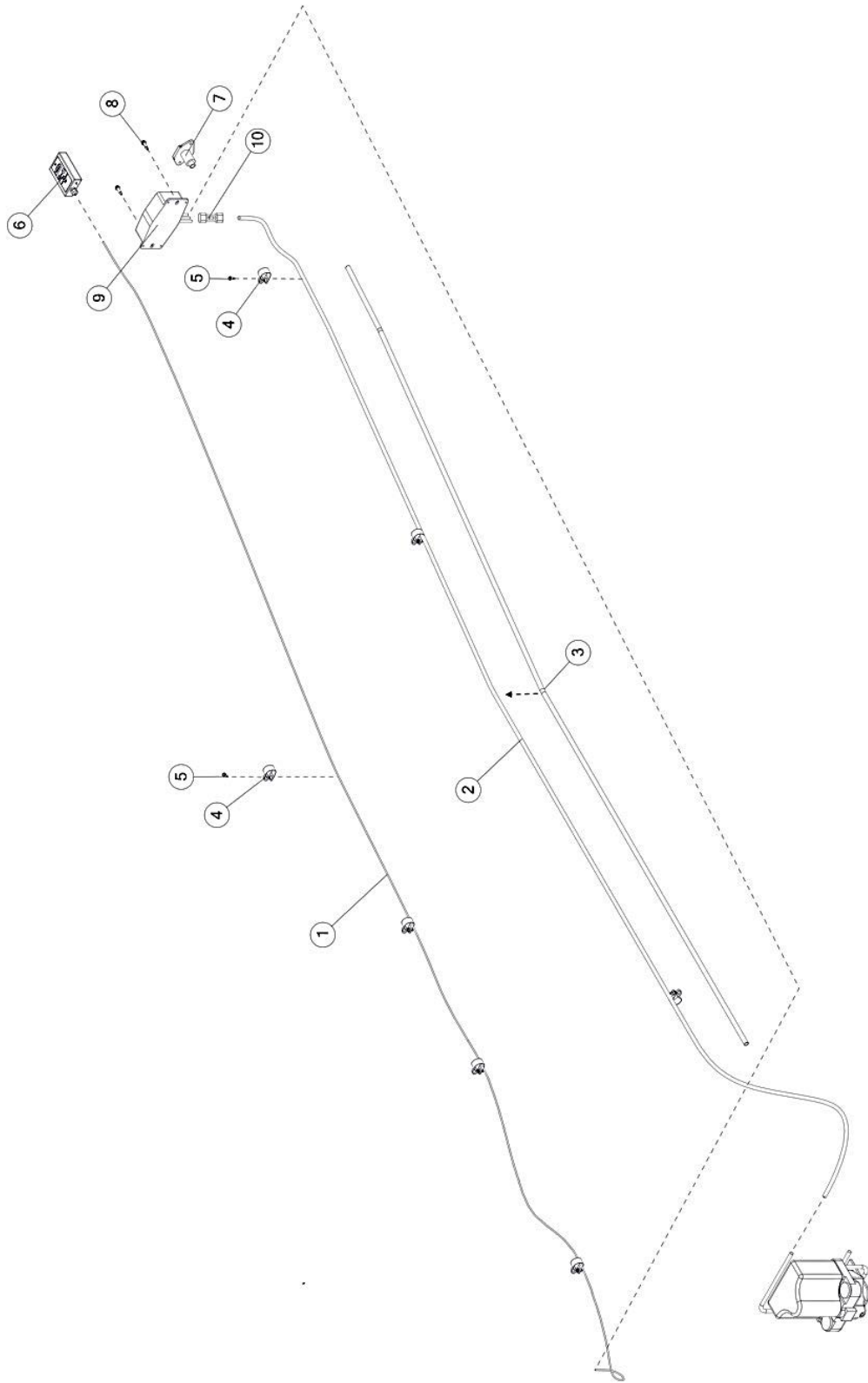

FIGURE 4

OPTIONAL BRAKE HARNESS ASSEMBLY

<u>ITEM</u>	<u>QTY</u>	<u>PART #</u>	<u>DESCRIPTION</u>
1	1	FBC30	BRAKE HARNESS
*	1	61043	EXTENSION HARNES 8 FEET
2	1	FBC40	EXTENSION HARNESS (4858900)
3	1	FBC42	EMT CONDUIT, 1/2 X 120
4	7	HGV72	CUSHION WIRE CLAMP
5	7	YSDR64005	SELF DRILLING SCREW, HEX WASHER HEAD, #10 X 5/8
6	1	FBC38	IN CAB CONTROLLER
7	1	8621	4 POLE TRAILER SOCKET
8	2	YSDR08005	SELF DRILLING SCREW, HEX WASHER HEAD, 1/4 X 1
9	1	FBC39	SD CONTROL MODULE (4834200)
10	2	57601	PRESSURE REDUCER FOR BRAKE SYSTEM

***MEANS NOT SHOWN**

FIGURE 5 OPTIONAL BRAKE LINE ASSEMBLY

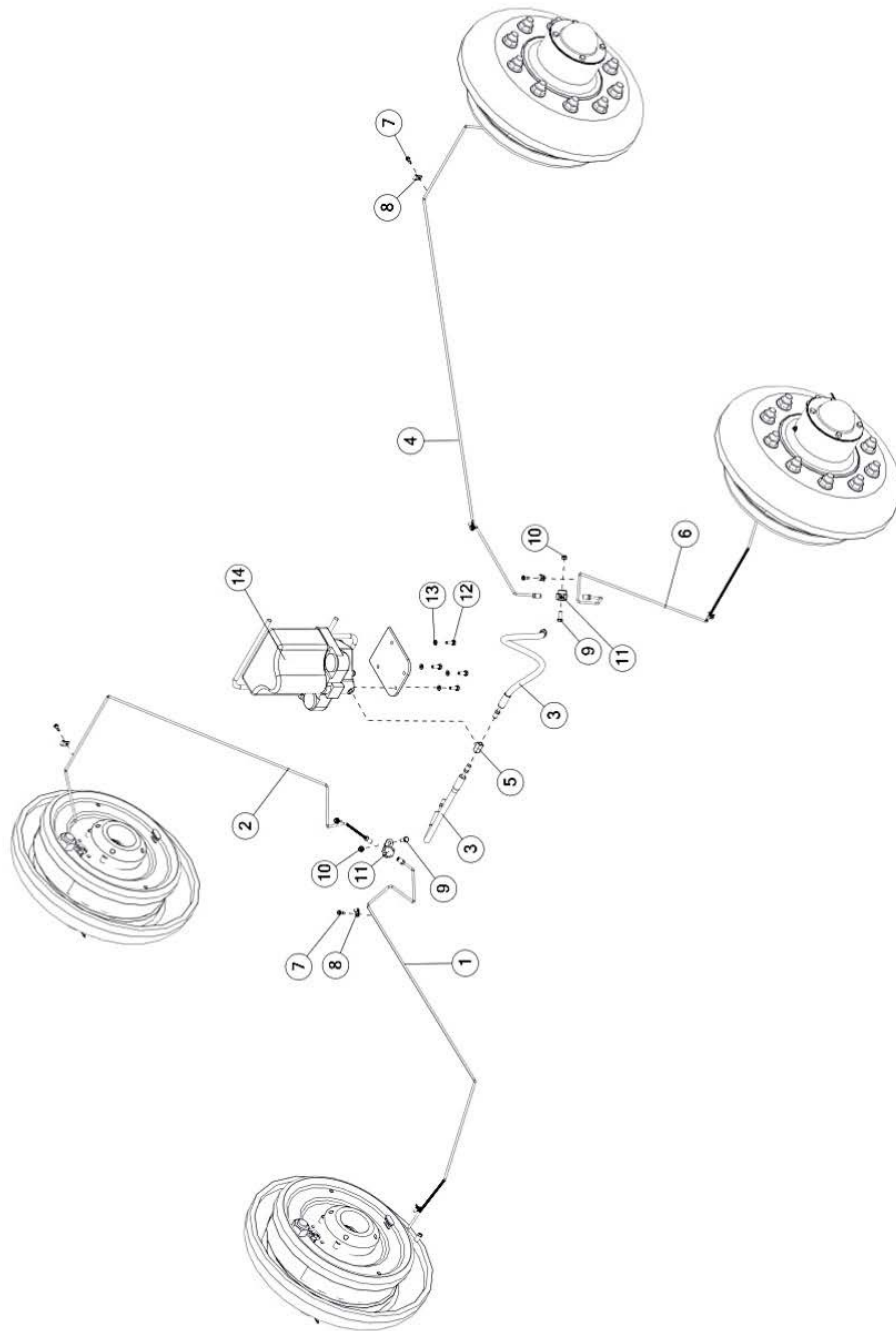

FIGURE 5
OPTIONAL BRAKE LINE ASSEMBLY

<u>ITEM</u>	<u>QTY</u>	<u>PART #</u>	<u>DESCRIPTION</u>
1	1	FBC44	HYDRAULIC BRAKE LINE (REAR)
2	1	FBC47	HYDRAULIC BRAKE LINE (60)
3	2	FBC46	HYDRAULIC BRAKE HOSE
4	1	FBC63	HYDRAULIC BRAKE LINE (57-1/2)
5	1	FBC45	BRANCH TEE
6	1	FBC62	HYDRAULIC BRAKE LINE (48)
7	8	YSDR64005	SELF DRILLING SCREW, HEX WASHER HEAD, #10 X 5/8
8	8	FBC64	LOOP CLAMP, 3/16 D LOOP
9	2	YBHH08100	BOLT HEX, 1/4 X 3/4 G5
10	2	YNNY08005	NUT HEX, NYLON LOCKNUT, 1/4
11	2	RGB26	TEE
12	4	YBHH08100	BOLT, 1/4 X 3/4 G5
13	4	YWLO08005	WASHER LOCK, 1/4
14	1	FBC41	BRAKERITE II (4834100)

FIGURE 6
OPTIONAL BRAKE ASSEMBLY

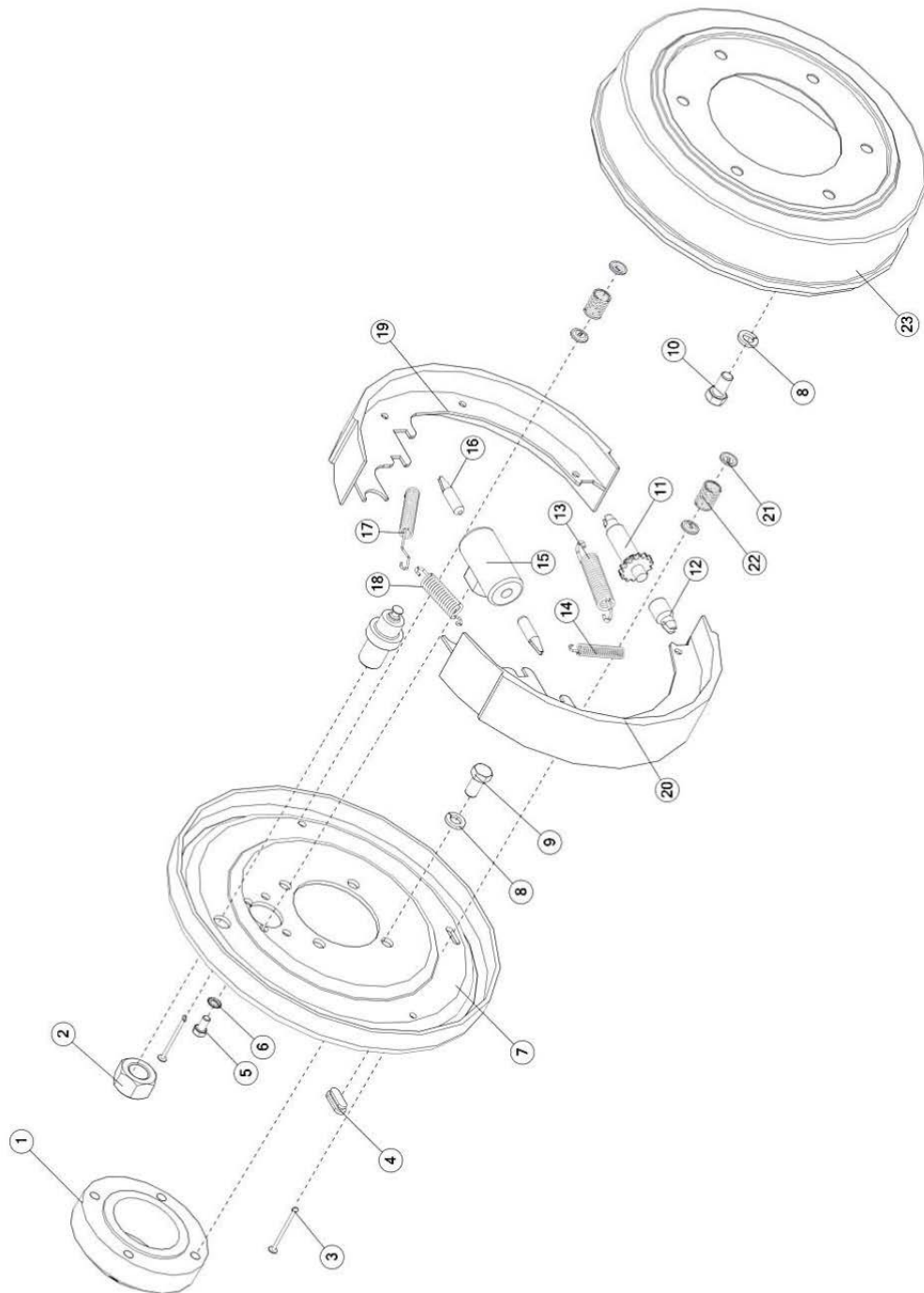

FIGURE 6

OPTIONAL BRAKE ASSEMBLY

<u>ITEM</u>	<u>QTY</u>	<u>PART #</u>	<u>DESCRIPTION</u>
1	1	CB17	BACKING PLATE MOUNT
2	1	YNHX32011	NUT HEX , 1
3	2	RGB56	PIN-SHOE HOLD DOWN
4	1	FBC55	ADJUSTING HOLE COVER
5	2	YBHH10132	BOLT HEX, 5/16 X 5/8
6	2	YWSI10005	WASHER, STAR LOCK, 5/16
7	1	FBC49	BRAKE RH (13 INCH)
8	4	YWLO16005	WASHER LOCK, 1/2
9	4	YBHH16010	BOLT HEX, 1/2 X 1 G5
10	6	YBHH16011	BOLT HEX, CAP SCREW, 1/2 X 1 G5
11	1	RGB49	ADJUSTING SCREW
12	1	RGB61	SOCKET
13	1	RGB50	SPRING ADJUSTING SCREW
14	1	RGB76	SPRING SHOE
15	1	FBC52	WHEEL CYLINDER LH
*	1	FBC53	WHEEL CYLINDER RH
16	2	FBC54	PUSH ROD
17	1	RGB55	SPRING SHOE
18	1	RGB75	SPRING LEVER
19	1	FBC50	BRAKE SHOE REAR
20	1	FBC50	BRAKE SHOE REAR
21	4	RGB57	CUP SHOE HOLD DOWN
22	2	RGB59	SPRING HOLD DOWN
23	1	RGE10	BRAKE DRUM (13 INCH)

***MEANS NOT SHOWN**

